

GW 750 VHM-Fasenfräser

Solid Carbide Chamfer End Mill
Fraise à chanfreiner en carbure monobloc
Fresa da smusso



DIN 6535
HA
HB
HE

$\lambda = 30^\circ$

2
Schneiden



VHM
GC 180

$\sigma = 120^\circ$

RG
51

Automaten-, Bau-, Federstahl			Einsatz-, Nitrier-, Vergütungsstahl			Werkzeugstahl (unlegiert, kalt-, warmarbeit, gehärtet)				rostfreier, hoch-warmfester Stahl		kov., rostfreier Stahlguss		Eisenguss				Ne-Metalle						Kunststoff (Thermo-, Duroplast, FVK)			Graphit	
A	B	F	E	N	V	U	K	W	G	R	H	K	R	GG	GGG	GTW	GTS	Al	Mg	Cu	CuZn	Bronze	Ampco	Ti	T	D	F	G
●	●		●	●	①							●		①	●	●	●	●	●	●	●	●	●	●				

Ausführung

Baumaße ähnl. DIN 6527-lang, 2 Schneiden, rechtsspiralgenutet, rechtsschneidend, 1 Schneide über Mitte, Zylinderschaft DIN 6535-HA

Schneidstoff / Beschichtung

GC 180 / ohne

Design

Dimensions sim. DIN 6527-long, 2 flutes, spiral fluted, right hand cut, 1 cutting edge over center, cylindrical shank DIN 6535-HA

Cutting material / Coating

GC 180 / none

Géométrie

Dimensions sembl. DIN 6527-série longue, 2 dents, hélice à droite, 1 dent passant au centre queue cylindrique DIN 6535-HA

Mat. Constituant l'outil / Revêtement

GC 180 / sans

Esecuzione

Dimensioni di costruzione simili a DIN 6527-lungo, 2 taglienti, scanalatura a spirale destra, destrotagliante, 1 tagliente attraverso medio, baretta cilindrica DIN 6535-HA

Materiale da taglio / rivestimento

GC 180 / senza

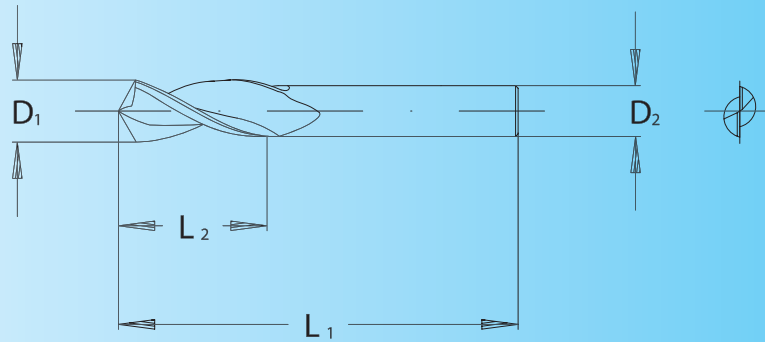

Artikel-Nr.	D1 e8 mm	D2 h5 mm	L1 mm	L2 mm	Preis EURO
0750030300	3	6	57	8	20,30
0750040300	4	6	57	11	20,30
0750050300	5	6	57	13	20,30
0750060300	6	6	57	13	20,30

Artikel-Nr.	D1 e8 mm	D2 h5 mm	L1 mm	L2 mm	Preis EURO
0750080300	8	8	63	19	43,70
0750100300	10	10	72	22	58,80
0750120300	12	12	83	26	63,10
0750160300	16	16	92	32	156,70
0750200300	20	20	104	38	208,50

Anwendungsmöglichkeiten:

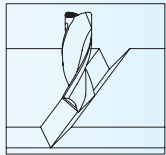

V-Nuten-Fräsen

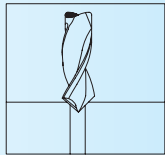

Senken

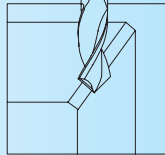

Fasen

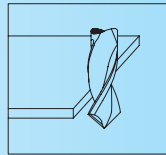

Umfangsfräsen

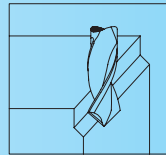

Umfangsfräsen
und Fasen

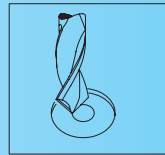

Zirkularfräsen

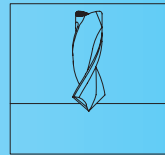

Anbohren

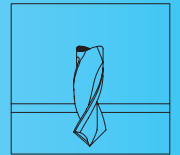

Bohren