

GW 4101 VHM-M-Gewindefräser

Solid Carbide M Thread milling cutter
Fraise à fileter M en carbure monobloc
Fresa a filettare cilindriche M in carburo solido



Automaten-, Bau-, Federstahl			Einsatz-, Nitrier-, Vergütungsstahl			Werkzeugstahl (unlegiert, kalt-, warmarbeit, gehärtet)				rostfreier, hoch-wärmfester Stahl		kov., rostfreier Stahlguss		Eisenguss				Ne-Metalle						Kunststoff (Thermo-, Duroplast, FVK)			Graphit	
A	B	F	E	N	V	U	K	W	G	R	H	K	R	GG	GGG	GTW	GTS	Al	Mg	Cu	CuZn	Bronze	Ampco	Ti	T	D	F	G
●	●		●	●	①							●	●	●	●	●	●	●	●	●	●	●	●	●	●	●	●	

Ausführung

Baumaße nach Werksnorm, 3-4 Schneiden, rechtsspiralgenutet, rechtsschneidend, ohne Stirnschnitt, Zylinderschaft DIN 6535-HA

Schneidstoff / Beschichtung
GC 180 / Vpr-EXX

Anwendung
Speziell zum Gewindefräsen.

Design

Dimensions acc. to work standard, 3-4 flutes, spiral fluted, right hand cut, without face cut, cylindrical shank DIN 6535-HA

Cutting material / Coating
GC 180 / Vpr-EXX

Application
Especially for thread milling.

Géométrie

Dimensions suivant normes standards, 3-4 dents, hélice à droite, coupe à droite, non coupe frontale, queue cylindrique DIN 6535-HA

Mat. Constituant l'outil / Revêtement
GC 180 / Vpr-EXX

Utilisation
Spécialement conçue pour fraise à fileter.

Esecuzione

Dimensioni di costruzione secondo norma della fabbrica, 3-4 taglianti, scanalatura a spirale destra, destrotagliante, barretta cilindrica DIN 6535-HA

Materiale da taglio / rivestimento
GC 180 / Vpr-EXX

Applicazione
Particolarmente per fresare a filettare.

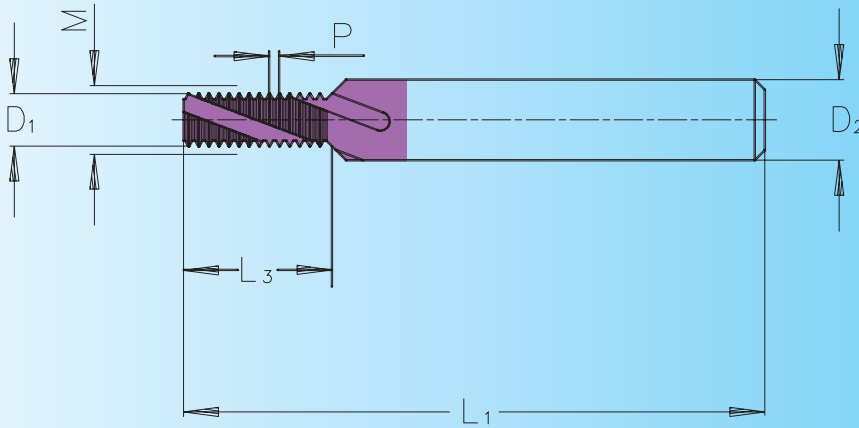

Artikel-Nr.	M	P	D1 mm	D2 h5 mm	L1 mm	L3 mm	Z	Preis EURO
4101030140	3	0,50	2,4	4	42	6,3	3	167,90
4101040140	4	0,70	3,15	6	55	8,8	3	124,60
4101050140	5	0,80	4	6	55	10,8	3	126,30
4101060140	6	1,00	4,8	6	55	12,5	3	149,30
4101080140	8	1,25	6	6	63	16,9	3	178,00
4101100140	10	1,50	8	8	70	20,3	3	199,80
4101120140	12	1,75	9,9	10	80	25,4	4	249,30
4101140140	14	2,00	11,6	12	90	29	4	276,20
4101160140	16	2,00	12	12	90	33	4	313,30
4101180140	18	2,50	14	14	90	38,8	4	360,40
4101200140	20	2,50	14	14	90	41,3	4	364,90