

GW 238 VHM-HSC-Radiuskopierfräser

Solid Carbide Ball Nose End Mill
Fraise à rayon en carbure monobloc
Fresa a raggio

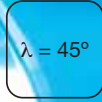

Automaten-, Bau-, Federstahl			Einsatz-, Nitrier-, Vergütungsstahl			Werkzeugstahl (unlegiert, kalt-, warmarbeit, gehärtet)				rostfreier, hoch-warmfester Stahl			kov., rostfreier Stahlguss		Eisenguss				Ne-Metalle						Kunststoff (Thermo-, Duroplast, FVK)			Graphit
A	B	F	E	N	V	U	K	W	G	R	H	K	R	GG	GGG	GTW	GTS	Al	Mg	Cu	CuZn	Bronze	Ampco	Ti	T	D	F	G
																		●	●	●	●	●	●	●	●	●	●	

Ausführung

Baumaße nach Werksnorm, Vollradius, 2 Schneiden, rechts-spiralgenutet, rechtsschneidend, 2 Schneiden zur Mitte, Zylinderschaft ähnl. DIN 6535-HA

Schneidstoff / Beschichtung

GC 120 / Vpr-ZOX plus

Design

Dimensions according to work standard, ball nose, 2 flutes, spiral fluted, right hand cut, 2 cutting edges to center, cylindrical shank similar DIN 6535-HA

Cutting material / Coating

GC 120 / Vpr-ZOX plus

Géométrie

Dimensions suivant normes standards, rayon, 2 dents, hélice à droite, coupe à droite, 2 dents passant au centre, queue cylindrique sembl. DIN 6535-HA

Mat. Constituant l'outil / Revêtement

GC 120 / Vpr-ZOX plus

Esecuzione

Dimensioni di costruzione secondo norma della fabbrica, raggio pieno, 2 taglienti, scanalatura a spirale destra, destrotagliante, 2 taglienti verso medio, barretta cilindrica simili DIN 6535-HA

Materiale da taglio / rivestimento

GC 120 / Vpr-ZOX plus

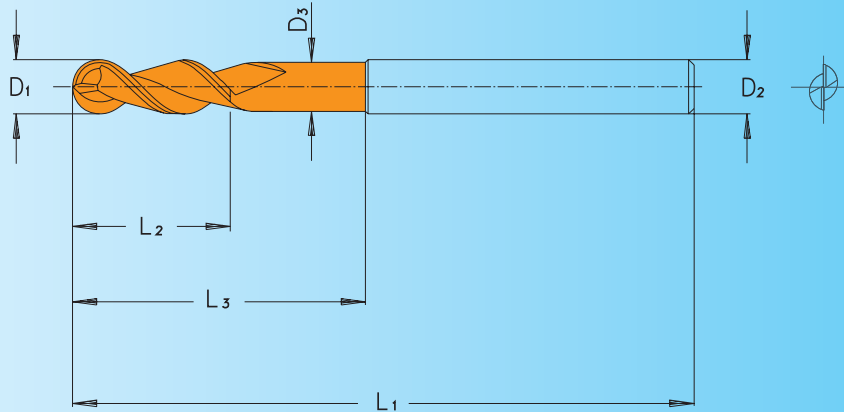

Artikel-Nr.	D1 f8 mm	D2 h5 mm	D3 mm	L1 mm	L2 mm	L3 mm	Preis EURO
0238030240	3	3	2,7	50	6	16	31,50
0238030340	3	3	2,7	75	10	32	45,90
0238030440	3	3	2,7	125	10	82	78,20
0238040240	4	4	3,7	54	7	17	37,60
0238040340	4	4	3,7	75	13	36	52,80
0238040440	4	4	3,7	125	13	86	89,90
0238050240	5	5	4,6	54	8	18	42,10
0238050340	5	5	4,6	75	15	40	60,90
0238060240	6	6	5,5	54	10	21	41,00
0238060340	6	6	5,5	100	16	44	55,60
0238060440	6	6	5,5	150	16	94	112,50
0238080240	8	8	7,5	59	12	27	52,30
0238080340	8	8	7,5	100	22	54	77,50
0238080440	8	8	7,5	150	22	104	140,10

Artikel-Nr.	D1 f8 mm	D2 h5 mm	D3 mm	L1 mm	L2 mm	L3 mm	Preis EURO
0238100240	10	10	9,4	67	13	32	68,60
0238100340	10	10	9,4	100	25	60	102,90
0238100440	10	10	9,4	150	25	110	166,00
0238120240	12	12	11,4	73	16	38	91,80
0238120340	12	12	11,4	100	26	60	133,00
0238120440	12	12	11,4	150	26	105	190,10
0238140240	14	14	13,2	75	16	38	113,90
0238140340	14	14	13,2	100	26	60	150,10
0238160240	16	16	15	83	20	44	147,70
0238160340	16	16	15	150	30	92	214,30
0238160440	16	16	15	250	30	192	361,40
0238200240	20	20	19	93	25	50	205,50
0238200340	20	20	19	150	40	92	299,00