

# GW 158 VHM-MF-Durchgangsbohrer

Solid Carbide Subland Core Thread Drill for clearance holes  
Foret étagé en carbure monobloc  
Punta multidiametro fori di passaggio

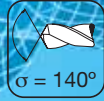

Automaten-, Bau-, Federstahl			Einsatz-, Nitrier-, Vergütungsstahl			Werkzeugstahl (unlegiert, kalt-, warmarbeit, gehärtet)				rostfreier, hoch-wärmfester Stahl		konv., rostfreier Stahlguss		Eisenguss				Ne-Metalle					Kunststoff (Thermo-, Duroplast, FVK)			Graphit		
A	B	F	E	N	V	U	K	W	G	R	H	K	R	GG	GGG	GTW	GTS	Al	Mg	Cu	CuZn	Bronze	Ampco	Ti	T	D	F	G
●	●		●	●	●	●	Ⓜ	Ⓜ				●		Ⓜ	●	●	●											

### Ausführung

spiralgenutet, rechtsschneidend  
Zylinderschaft DIN 6535-HA  
Stufenlänge nach DIN 8376

### Schneidstoff / Beschichtung

GC 150/Vipr-VS

### Anwendung

Für Durchgangslöcher

### Design

spiral fluted, right hand cut  
cylindrical shank DIN 6535-HA  
length of step acc. to DIN 8376

### Cutting material / Coating

GC 150/Vipr-VS

### Application

For clearance holes

### Géométrie

goujure spiralé, coupe à droite  
queue cylindrique DIN 6535-HA  
avec longueur d'étage svt. DIN 8376

### Mat. Constituant l'outil / Revêtement

GC 150/Vipr-VS

### Application

Pour trous de passage

### Esecuzione

scanalato a spirale, destrotagliante  
Barretta cilindrica DIN 6535-HA  
Lunghezza di gradini secondo DIN 8376

### Materiale da taglio / rivestimento

GC 150/Vipr-VS

### Applicazione

Per i fori di spazio

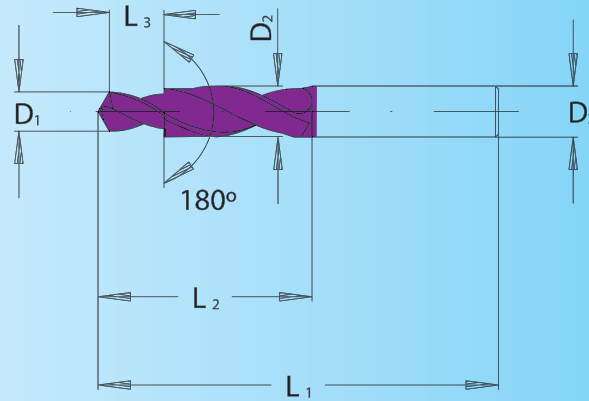

Artikel-Nr.	D1 h7 mm	D2 h7 mm	D3 h5 mm	L1 mm	L2 mm	L3 mm	Preis EURO
0158034340	3,4	6	6	66	28	9	52,10
0158045340	4,5	8	8	79	41	11	80,60
0158055340	5,5	10	10	89	47	13	104,10
0158066340	6,6	11	10	102	55	15	150,10

Artikel-Nr.	D1 h7 mm	D2 h7 mm	D3 h5 mm	L1 mm	L2 mm	L3 mm	Preis EURO
0158090340	9	15	14	115	65	19	250,70
0158110340	11	18	18	123	73	23	290,80
0158135340	13,5	20	20	131	79	27	374,30